

# **PT-W, PD-W, PD-WBK, PD-N and PD-NBK**

**TRANSDUCERS**

**INSTALLATION MANUAL**

**LEI**  
**ACCESSORIES**  
FOR LOWRANCE, EAGLE, AND SEA ELECTRONICS PRODUCTS

### **NOTICE**

When the transducer is mounted on the outside of the hull, periodically wash the transducer's face with soap and water to remove any oil film that may collect. Oil and dirt on the face will reduce the sensitivity or may even prevent operation.

**Copyright © 1995, 1996 Lowrance Electronics, Inc.  
All rights reserved.**

# PT-W INSTALLATION INSTRUCTIONS ONLY

The PT-W is a wide cone angle (20 degree) transducer designed to be used with portable sonar units.

Assemble the transducer and bracket as shown below. Press the rubber grommet into the hole in the top of the bracket. Tie one end of the lanyard through this hole.

To use the PT-W, choose an area on the transom that is free from air bubbles when the boat is moving. Although this is not a high speed transducer, it will operate when the boat is moving faster than trolling speeds. It is important to mount the transducer in an area that is free from air bubbles, since they cause interference on the sonar's display.

Once a good location is found, clean the area before attaching the suction cup. Moisten the suction cup and press it firmly onto the hull. The suction cup should be mounted just above the bottom edge of the hull. This allows the transducer a good chance to be in smooth water at all times.

Tie the lanyard to the boat. This will prevent the loss of the transducer if the suction cup comes loose. Route the transducer cable to the sonar unit.

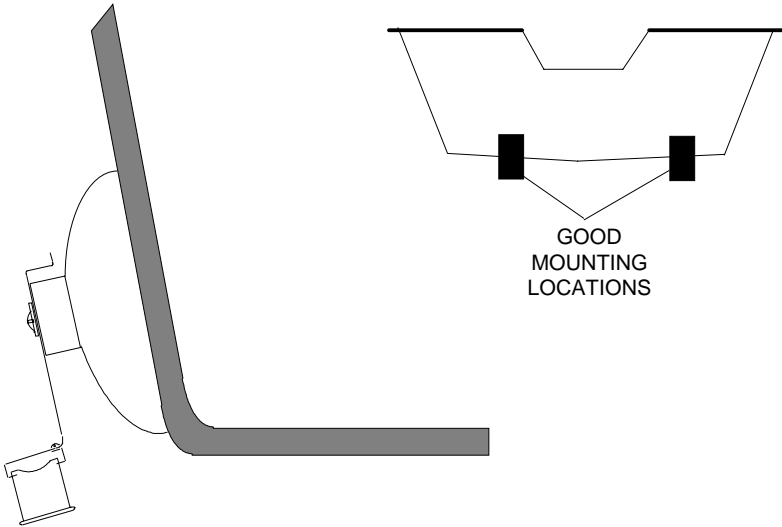

## PD-W & PD-N INSTALLATION INSTRUCTIONS

The PD-W and PD-WBK are wide cone angle (20 degree) transducers and can be mounted to shoot through the hull, or, with an automotive hose clamp, attached to a trolling motor. The PD-N and PD-NBK narrow cone angle (8 degree) transducers are shoot-thru-hull mount only.



Read this manual carefully before attempting the installation. Use extreme care if mounting the transducer inside the hull, since once it is epoxied into position, the transducer usually cannot be removed. Remember, the transducer location is the most critical part of a sonar installation. If it isn't done properly, the sonar can't perform at it's designed potential.

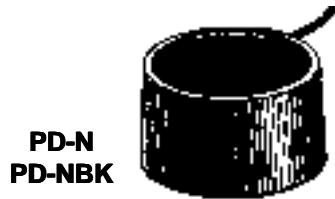

### Location - General

1. The transducer must be placed in a location that has a smooth flow of water at all times. If the transducer is to be mounted inside the hull, then the chosen location must be in the water at all times. If the transducer is not placed in a smooth flow of water, interference will show on the sonar's display in the form of random lines or dots whenever the boat is moving.
2. The transducer should be installed with it's face pointing straight down, if possible.
3. If possible, route the transducer cable away from other wiring on the boat. Electrical noise from engine wiring can be displayed on the sonar's screen. Noise from bilge pumps and aerators can also be picked up, so use caution when routing the transducer cable around these wires, also.

# SHOOT-THRU-HULL

The transducer installation inside a fiberglass hull must be in an area that does not have air bubbles in the resin or separated fiberglass layers. The sonar signal must pass through solid fiberglass. A successful transducer installation can be made on hulls with flotation materials (such as plywood, balsa wood, or foam) between layers of fiberglass if the material is removed from the chosen area. For example, some manufacturers use a layer of fiberglass, then a core of balsa wood, finishing with an outer layer of fiberglass. Removing the inner layer of fiberglass and the balsa wood core exposes the outer layer of fiberglass. The transducer can then be epoxied directly to the outer layer of fiberglass. Epoxy is poured into the hole and the transducer is then placed into the epoxy. After the epoxy cures, the hull is watertight and structurally sound. Remember, the sonar signal must pass through solid fiberglass. Any air bubbles in the fiberglass or the epoxy will reduce or eliminate the sonar signals.

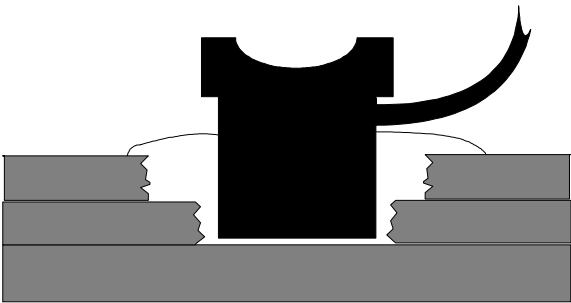

To choose the proper location for thru-hull mounting, anchor the boat in 60 feet of water. Add a little water to the sump of the boat. Plug the transducer into the sonar unit, turn it on, then hold the transducer over the side of the boat. Adjust the sensitivity and range controls until a second bottom echo is seen on the display. (you will need to turn the automatic and ASP functions off on L.C.G. units.) Don't touch the controls once they've been set. Next, take the transducer out of the water and place it in the water in the sump of the boat. Observe the sonar signal to see if there is a noticeable decrease in sensitivity. The second bottom signal may disappear and the bottom signal may decrease in intensity. Move the transducer around to find the best location. If the sensitivity control has to be increased greatly to compensate, then a different type of transducer should be mounted on the outside of the hull. If not, then mark the location that shot through the hull the best and follow the instructions below for a thru-hull mounting.

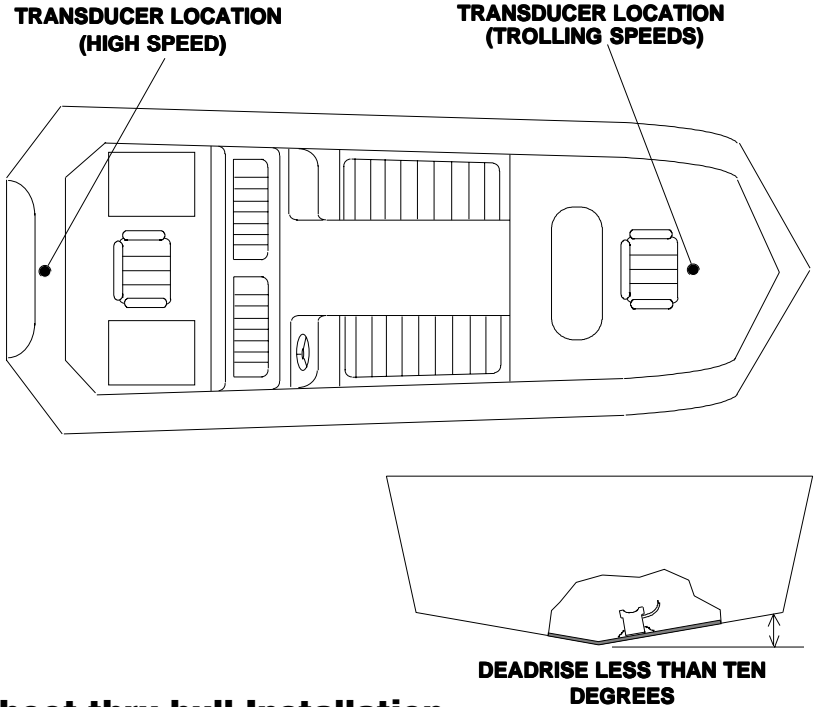

## Shoot-thru-hull Installation

1. Dry the chosen area thoroughly, then sand both the inside surface of the hull and the face of the transducer with 100 grit sandpaper. The surface of the hull must be flat so the entire transducer face is in contact with the hull prior to bonding.
2. Make certain the area is clean, dry, and free of oil or grease. Build a small dam out of caulking compound or RTV around the mounting area. It should be at least 1/2" greater in diameter than the transducer. Use a good two-part epoxy that sets up rock hard. Do not use 5 minute or "fast setting" epoxy. Do not use RTV silicone rubber adhesive or any other glue.

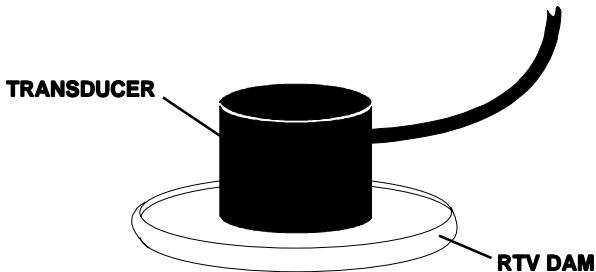

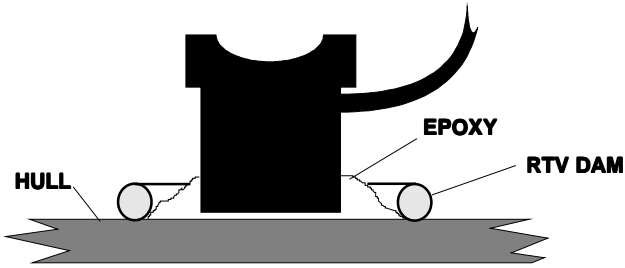

3. Follow the instructions on the epoxy package and mix it thoroughly. Do not mix it too fast, as it will cause bubbles to form in the epoxy. Apply a small amount on the entire face of the transducer, then pour 1/16" level into the area contained by the dam. Place the transducer into the epoxy, twisting and turning it to force any air bubbles out from under the transducer face. The face of the transducer should be parallel with the hull, with a minimum amount of epoxy between the hull and transducer. Hold the transducer down with a weight until the epoxy dries. Afterwards, route the cable to the sonar unit.

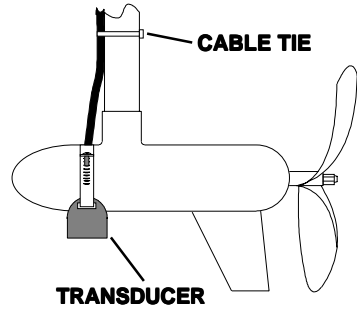
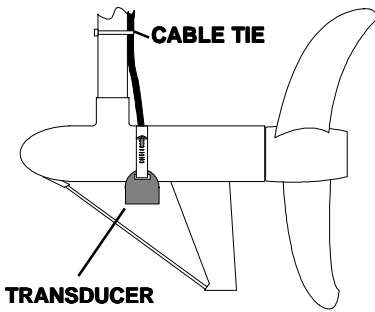

## **Trolling Motor Mount - PD-W Only**

The top of the transducer is curved to fit the contour of the motor on electric trolling motors. Attach it using a automotive hose clamp available at any auto parts store.

1. Measure the diameter of your trolling motor and purchase a hose clamp slight larger.
2. Determine the mounting location. It should be ahead of the skeg. Water turbulence is at a minimum at this position. Some trolling motors have a wire brace from the motor to the skeg. The transducer won't be affected by this.
3. Position the transducer to aim straight down with the cable angled away from the direction of travel. Mount it with the hose clamp.
4. Tie the cable to the motor shaft using plastic cable ties (available at automotive or electrical supply stores). Be certain there is enough slack for the motor to turn freely.